

We've been working with lab managers and lab architects since 1981, and we design and manufacture made-to-order furniture for every lab's unique requirement. In addition to modular lab benches, the casework is one of the main players when furnishing a lab, as they go along the wall and offer a stable solution to any lab application.

At Formaspace, the casework offerings can be fabricated to industry-standard sizes and made to fit equipment, tools, shelving, and technology. The casework can be built with steel and the choice of powder coating finishes.

Contact us today for your next casework project.



Base Cabinets

- | | |
|--|--|
| 1 20 ga removable back panels | 8 Roller catches |
| 2 20 ga single-piece drawer box | 9 5-knuckle stainless hinges |
| 3 18 ga side panels | 10 Full-extension ball-bearing drawer slides |
| 4 16 ga top rails | 11 3/8-16 leveling feet |
| 5 18 ga removable bottom | |
| 6 20 ga double pan sound damped door & drawer fronts | |
| 7 18 ga full-depth adjustable shelf | |

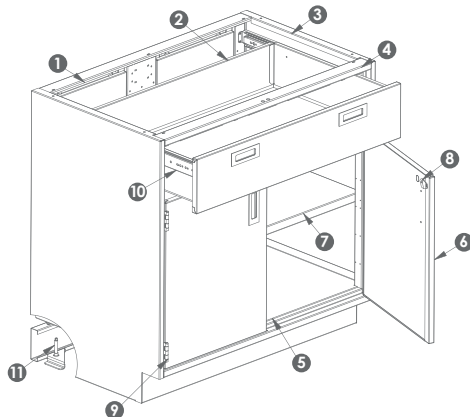

Wall Cabinets

- | |
|--|
| 1 18 ga back panel & hat stiffeners |
| 2 18 ga side, top, bottom panels |
| 3 18 ga false bottom |
| 4 18 ga adjustable shelves |
| 5 20 ga double pan sound damped door & drawer fronts |
| 6 Wall hanging cleat included |
| 7 5-knuckle stainless hinges |
| 8 Roller catches |

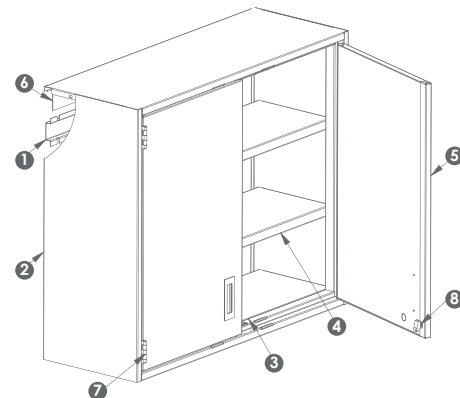

CASEWORK COUNTERTOPS

Phenolic resin countertops

Black

Gray

White

Epoxy resin countertops

Black

Gray

White

Stainless steel countertops

Stainless steel

POWDER COAT FINISH OPTIONS

